



15W WPC Wireless Power Receiver

Features

- ◆ Single Chip WPC1.2.4 Wireless Power Receiver for 15W application
- ◆ Vrect Range: 4-24V Operational, 28V Max
- ◆ 15W Maximum Output Power
- ◆ Fully Synchronous Rectifier Optimized for Multi-Mode Operation
- ◆ Integrated Buck Regulator with Fine Vout Steps and High-Efficiency Bypass Mode
 - Range 1: 4.940-10.040V in 20mV steps
 - Range 2: 7.410-15.060V in 30mV steps
 - Range 3: 9.880-20.080V in 40mV steps
- ◆ Comprehensive Power Regulation
 - Output Current Regulation in CC Mode
 - ◆ 100mA to 1000mA in 50mA steps
 - ◆ 1000mA to 2200mA in 100mA steps
 - Input Impedance Regulation to Maintain Vrect Voltage
- ◆ Very Low Standby Current: 7µA Typical
- ◆ I²C Interface with SM, FM and FM⁺ Modes
- ◆ Optional PSNS Generation for Downstream Charging Current or Power Regulation
- ◆ Comprehensive Protection
 - 6-channel ADC for Comprehensive Power and Temperature Monitoring
 - Programmable Input and Output Power Regulation
 - Output Over-Current Protection (OCP)
 - Vrect Over-Voltage Protection (OVP)
 - Over Temperature Protection (OTP)
- ◆ 3.5mm x 3.5mm 64-Bump Package (WLCSP), 0.59mm Height

Applications

- Mobile Devices
- Wireless Charging Accessories

Order Information

Part Number	Device ID	I2C Address	Max Output Power	Default Vout	Default LDOP	Package	Packing Method
HL6111RWLWPF1	0x10	0100101	15W	9V	1.8V	WLCSP-64	Tape & Reel
HL6111RWLWPF2	0x01	0100101	15W	12V	1.8V	WLCSP-64	Tape & Reel
HL6111RWLWPF3	0x00	0100101	15W	12V	3.3V	WLCSP-64	Tape & Reel
HL6111RWLWPF5	0x11	0100101	15W	15V	1.8V	WLCSP-64	Tape & Reel

For other options, contact a Halo Microelectronics sales representative.



Typical Application Diagram

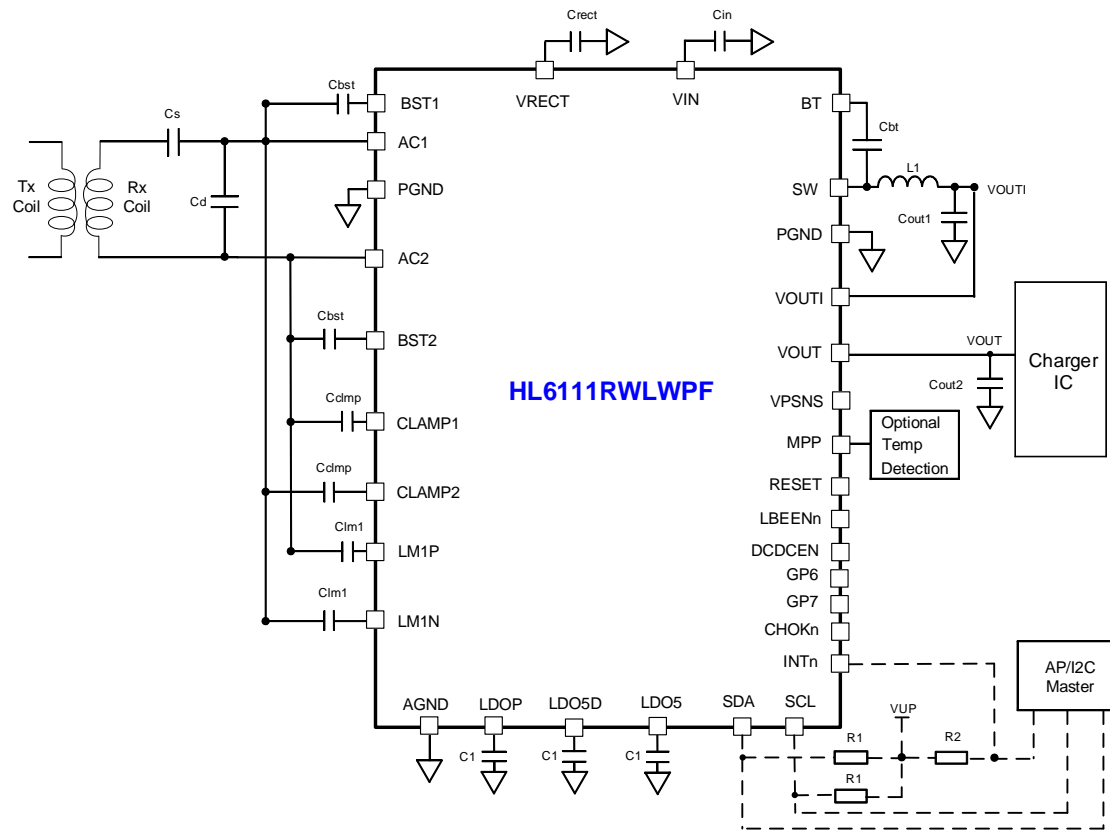

Figure 1 HL6111RWLWPF Typical Application and Functional Diagram

Component	Part Number	Value	Size	Vendor
L1	See Table2	1uH-2.2uH	2016	See Table2
Crect	C2012JB1H475K125AB	4.7uF /50V	0805	TDK
Cin	C2012JB1H475K125AB	4.7uF /50V	0805	TDK
Cout1	C2012JB1H105K085AB	1uF /50V	0805	TDK
Cout2	C2012JB1H475K125AB	4.7uF /50V	0805	TDK
Cbt	CGJ3E2X7R1C104K080AA	100nF /10V	0603	TDK
C1	C1608JB1A105K080AC	1uF-4.7uF /10V	0603	TDK
Cbst	CGJ3E2X7R1C333K080AA	33nF /10V	0603	TDK
Cclmp	C2012X6S1H474M125AB	470nF /50V	0805	TDK
Clm1	C2012C0G1H223J125AA	22nF /50V	0805	TDK
R1	--	2.2-4.7kΩ	--	--
R2	--	2.2-4.7kΩ	--	--

Table 1 Recommended External Components



Manufacturer	Part Number	L (uH)	DCR(mΩ)	I _{MAXDC} ⁽¹⁾	Component Dimension		
					L (mm)	W (mm)	H (mm)
MURATA	DFE252012F-1R0M	1	40	4.7	2.5	2.0	1.2
CYNTEC	HMLQ20161B-1R0MDR	1	50	3.0	2.0	1.6	1.0
CYNTEC	PCSB25201T-1R5MS	1.5	84	2.9	2.0	2.5	1.0
TDK	TFM252010GHM-2R2MTAA	2.2	85	2.8	2.5	2.0	1.0

Table 2 Recommended Inductors

Manufacturer	Part Number	L(uH)	DCR(mΩ)	Q-Factor	Component Dimensions		
					L (mm)	W (mm)	H (mm)
SUNLORD	MQQRR505012S8R2IDD	8.2	85	60	50	50	1.2
LINE PRINTING	Y01	8.5	326	16	48	48	0.26

Table 3 Recommended WPC Receiver Coil

Notes:

1. I_{MAXDC} is the smaller current to produce 40°C temperature rise or 30% effective inductance reduction.



Description

HL6111RWLWPF is a highly integrated wireless charging power receiver IC that is compatible with popular wireless charging power delivery standards: Wireless Power Consortium V1.2.4 (WPC/Qi) standard. It integrates a fully synchronous rectifier and a high-performance buck post regulator with bypass mode to deliver a maximum of 15W with best-in-class conversion efficiency, while providing maximum design flexibility between the wireless charging receiver (Rx) coil design and output voltage to match down-stream Li-Ion battery charge ICs.

The output voltage of HL6111RWLWPF can be programmed with fine steps of 20mV, 30mV or 40mV to accommodate a wide variety of Li-ion battery chargers, including switch-mode chargers and charge-pump chargers. It also includes output constant-current (CC) mode in steps of 50mA/100mA for ease of usage. On the input side, an input impedance control scheme is included so that the Rx coil output voltage V_{rect} does not collapse when output load is suddenly increased. As an option, HL6111RWLWPF also provides a PSNS output

voltage which is proportional to its output current or power, so that down-stream charger can use this information to control its power delivery to the battery.

A 6-channel 10b ADC monitors the input and output power, die temperature, etc. information, as well as an external MPP channel to ensure safe operation under different operational modes and power conditions. The IC also includes input over-voltage, output over-current, die over-temperature and coil over-temperature protection mechanism.

HL6111RWLWPF includes an I2C interface with SM, FM and FM+ support, a highly flexible digital processing unit and one-time-programmable (OTP) memory cells so that system level controllability, programmability and flexibility are maximized.

The HL6111RWLWPF is available in a 64-bump, 0.4mm pitch, Wafer-Level Chip-Scale package (WLCSP).



Important Notice

Halo Micro reserves the right to modify, improve and terminate its products, service, documentation, etc. without advance notice. Customers are encouraged to contact HALO Micro sales representative get the latest product information.

Without proper legal authorization, Halo Micro products shall not be used for medical or military applications. Halo Micro does not assume any liability of personal or property damages of any kind due to such applications.

All text, images, trademarks of this document, and any intellectual property contained in the product and in this document, belong to Halo Micro Co. Ltd. No part of this document may be used, copied, modified, distributed or published without legal authorization from Halo Micro.